

Universal Locking Electronics ULC

Customer configurable with 2 MHz bandwidth

IMRA America offers a user-friendly 5 channel PID lockbox, combined with a GPS disciplined, tunable RF synthesizer. Integrated phase detectors, selectable pre-scalers, and RF bandpass filters allow for plug and play solutions of even the most demanding locking applications.



Features

- 3 selectable bandpass filter frequencies (frequencies can be factory set)
- 5 selectable pre-scalers from 1 - 16
- Configurable for f_{beat} and f_{ceo} locking, f_{rep} and f_{ceo} locking, f_{rep} -only locking
- GPS reference input
- Internal RF synthesizer from 10 - 70 MHz (for f_{ceo} and f_{beat} locking) and from 0.99 - 1.01 GHz (for f_{rep} locking), disciplined to GPS
- Support for up to three cascaded PID filters (two cascaded PID filters in channel 1) for utilization of actuators with different bandwidths
- Configurable for phase locking with RF signal or error signal input

Compatible with General Metrology Applications

- Frequency comb locking
- Locking to optical and microwave references
- Pound-Drever Hall locking
- Coherent control
- Coherent dual comb operation

ULC Specifications	
Capability	configurable for full control (f_{beat} and f_{ceo}) or (f_{rep} and f_{ceo})
Number of Channels	5 (2 Independent)
Channel Bandwidth	Up to 2 MHz
GPS Reference Signal	Via SMA connector at 10 MHz
RF Signals in Range, Up to Two	10 MHz - 1 GHz; OdBm
Director Error Signal Input in Range, Optional	$\pm 3V$
System Size	19", 2U rack-mountable, 18" long
Power Consumption	< 50 W

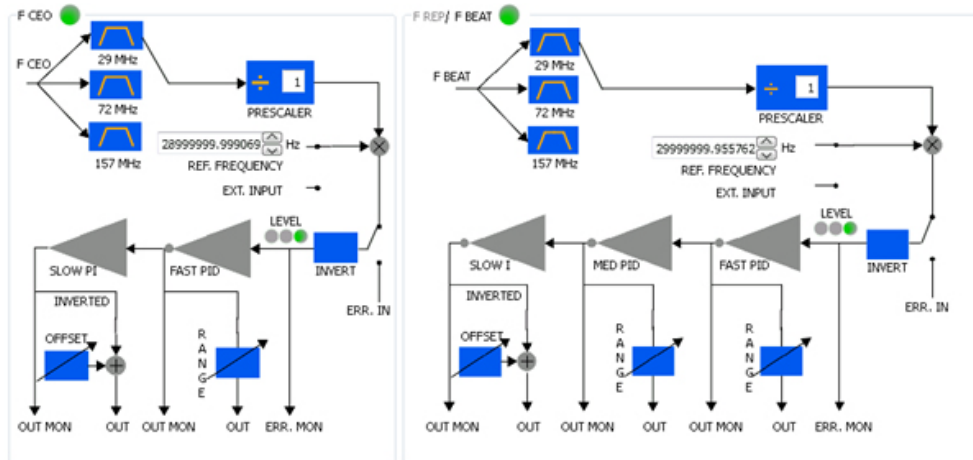

Graphic representation of configuration options as seen on a computer interface

Configuration options (as used for combs)

- 4 different configurations selectable via PC
- Repetition rate locking via f_{beat} with optical reference or via locking of harmonic of f_{rep} to RF reference near 1 GHz
- Choose tunable internal or external RF references
- Internal RF references optionally disciplined to GPS
- Frequency or phase lock of f_{ceo} at selectable frequency



Front panel of ULC with E-comb 250R



IMRA America, Inc.

1044 Woodridge Ave., Ann Arbor, MI 48105 Phone: 734.930.2560 Fax: 734.930.9957

combs@imra.com

www.imra.com